



Service Kit

753-04230

CODE: R-479

DATE: August 13, 2002

SUBJECT: 46" Deck Spindle Replacement

MODELS 800 Series AutoDrive Models
AFFECTED: w/ Step Through Frame, 46" Deck and Electric PTO.

PURPOSE: This kit is to be used when it is found that the upper deck drive belt is being thrown-off or damaged during operation in the lowest cutting positions. The failure is due to the angle the belt travels from the PTO Idler pulley to the RH blade spindle.

NOTE: These materials are prepared for use by trained technicians who are experienced in the service and repair of equipment of the kind described in this publication, and are not intended for use by untrained or inexperienced individuals. Such individuals should seek the assistance of an authorized service technician or dealer.

Typical Installation Time: 75 Minutes

Service Kit Contents

REF. NO.	PART NUMBER	QTY	DESCRIPTION
1	618-0595	2	Spindle Assembly, Double Pulley
2	783-1347	1	Cover: Belt; LH: 46" GT
3	710-0778	3	Screw: TT: 1/4-20 x 1.50 HXINDWSH
4	750-0755	3	Spacer: .330ID x .625 OD x .915 LG
5	710-0859	1	Screw: Hex Head: 3/8-16 x 2.50: GR 5
6	750-0497	1	Spacer: .375 ID x .625 ODx

Pre-Service Preparation:

1. Turn ignition switch to the off position and remove the key.
2. Depress brake pedal and push the Parking Brake button to engage brake.
3. Allow the engine and muffler to cool before proceeding.
4. Remove the spark plug wire(s) from the plug(s) and clip to the engine block.

Removal Instructions: Retain all parts except as noted.

1. Set two 2" x 4" blocks under deck with 4" side on ground. Lower deck so that deck is setting on the blocks.
2. Remove the engine to deck drive belt from the PTO by moving the idler to relieve tension on the belt.
3. Release the two "J" hooks at the back of the deck.
4. Slide deck forward slightly to release front of deck from the stabilizer rod. Remove deck from under rider.
5. Remove 6 self-tapping screws that secure the left hand (LH) and right hand (RH) Belt Covers using a 3/8" socket. Discard the LH Belt Cover only. Remove the upper drive belt from the LH and RH Spindle Assemblies.
6. Make a sketch of the correct belt routing for re-installation. Remove the lower blade drive belt from the 3 deck pulleys by moving the blade belt tensioning idler to relieve tension on the belt.

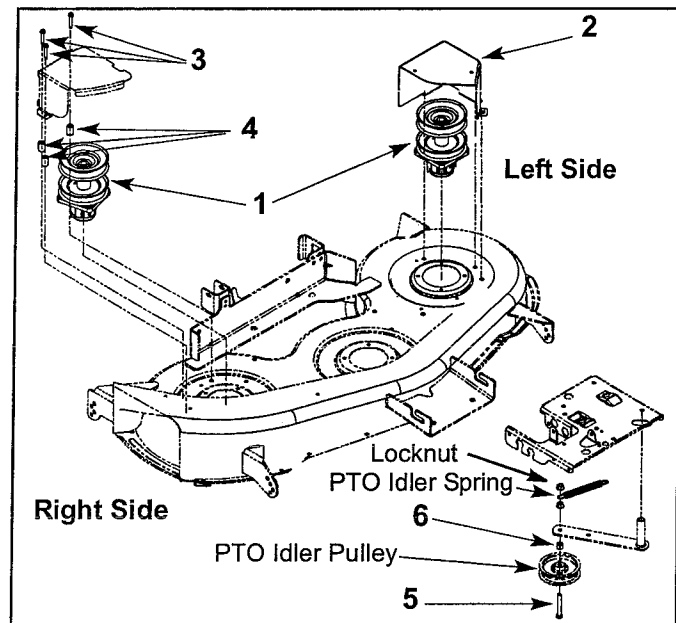

FIGURE 1

7. Remove the blades, using a 15/16" socket, from the left and right hand spindles.
8. Remove the four (4) self tapping screws that retain the left hand Spindle Assembly using a 1/2" socket. Save the screws and spindle plate for re-use. Discard the spindle assembly only.
9. Repeat Step 8 for the right hand Spindle Assembly.

Installation Instructions:

10. Position a new Spindle Assembly, Item 1, in either spindle location. Position the spindle plate, removed in Step 9, from the underside of the deck. From the underside of the

- deck install four (4) self tapping screws (Ref. 710-0650) removed in Step 8. Torque each screw to 200-300 In-Lbs.
11. Repeat Step 10 for the opposite side.
 12. Re-install both blades. Torque the blade retaining nuts (Ref. 712-0417A) to 70-90 Ft.-Lbs.
 13. Inspect upper and lower deck drive belts for wear, cracks broken cords or pieces missing. replace if required.
 14. Re-install the lower drive belt per routing sketch.
 15. Install the upper drive belt around the two upper pulleys on the RH and LH Spindle Assemblies.
 16. Install the new LH Belt Cover, Item 2, using the screws (Ref. 710-0599) removed in Step 5. Carefully tighten screws securely.
 17. Place the three (3) Spacers, Item 4, over the mounting holes in the deck where the RH Belt Cover will mount.
 18. Set the existing RH Belt Cover on the Spacers.
 19. Using the three (3) 1/4-20 x 1.5" Lg. Screws, Item 3, attach the RH Belt Cover. Carefully tighten screws securely.
 20. Refer to Figure 1. Remove the top locknut (Ref. 712-0431) from the PTO Idler Pulley Screw using a 3/8" socket. Disconnect the PTO Idler Spring from the idler arm. Remove the second nut from the PTO Idler Pulley Screw. Remove and discard the PTO Idler Pulley screw.
 21. Using the new 3/8-16 x 2.5" screw, Item 5, re-install the idler pulley with the Spacer, Item 6, between the pulley and the idler arm as shown. Fasten with one locknut removed in Step 19.
 22. Reconnect PTO Idler Spring to top of PTO Idler Pulley screw. Install second locknut to top of PTO Idler Pulley Screw, Item 5.
 23. Reinstall deck on rider in reverse order of removal.

Post Installation Inspection:

1. Check for proper routing of upper and lower deck drive belt and compare with Owner's Manual.
2. Raise deck to highest position.
3. Place transmission in neutral.
4. Ensure brake is engaged and locked on.
5. Ensure the PTO switch is in the OFF position. Start unit. Set throttle to full speed.
6. Deck blades must not be rotating. If blades are not rotating proceed to Step 9. If blades are rotating turn key off and allow blades to stop fully. Proceed to Step 7.
7. Troubleshoot electrical and clutch systems. Repair as necessary.
8. Repeat Steps 2 through 6.
9. Turn PTO switch to the ON position. The electric PTO clutch should engage and blades rotate.
10. Raise and lower the deck through it's full range while blades are running. There should be no vibration and the deck should raise and lower smoothly.

11. Lower the deck to it's lowest position and disengage the electric PTO. Blades must stop quickly. Turn PTO switch to the ON position again. Repeat Steps 10 and 11 several times.
12. There should be no vibration, no belt loss or belt damage. If there is vibration, belt loss or damage troubleshoot and repair as necessary. Repeat Steps 9 through 11.

NOTES