

Service Kit 753-0673

Code: CP-020

Date: July 22, 1996

Subject: Shredder/Chipper-Shredder
Vacs

THIS KIT IS INTENDED TO BE USED WHEN
THE CHIPPING FEATURE BECOMES
DIFFICULT OR INOPERABLE

SHREDDER SHIM INSTALLATION INSTRUCTIONS

Install Service Kit as follows:

1. Disconnect the spark plug wire and move it away from the spark plug.
2. Loosen the two hand knobs on each side of the chute deflector. Lift the chute deflector and tie it out of the way.
3. Remove the flail screen by removing the two hairpin clips from the clevis pins which extend through the housing. Remove the clevis pins. Lift the flail screen from inside the housing.
4. Remove the chipper chute by removing three hex nuts and washers. A 1/2" wrench is required.
5. Rotate the impeller assembly by hand until you locate one of the chipper blades in the chipper chute opening. Remove the blade, using a 3/16" allen wrench on the outside of the blade and 1/2" wrench on the impeller assembly (inside the housing). See figure 1.

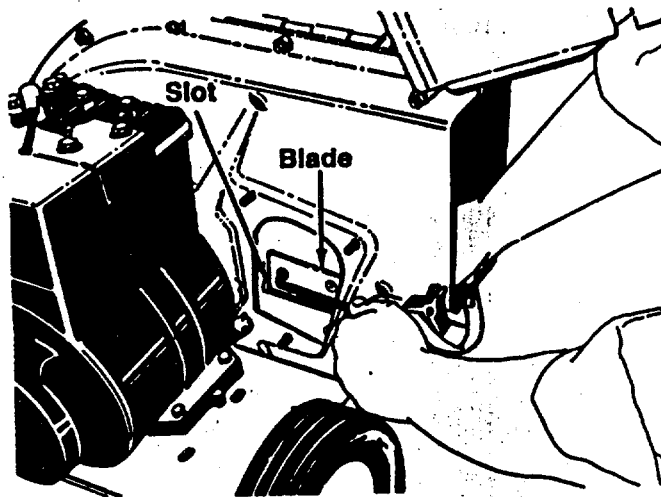

Fig. 1

6. Remove the other blade in the same manner.
7. Position shim against the impeller and re-install blades with the hardware removed in step 5. Torque hardware to 250-350 inch pounds.

NOTE: Make certain the blades are reassembled with the sharp edge facing toward the slotted opening in the impeller assembly.

770-0314M

4. Remove the belt cover on the front of the engine by removing the two self-tapping screws. See figure 3.

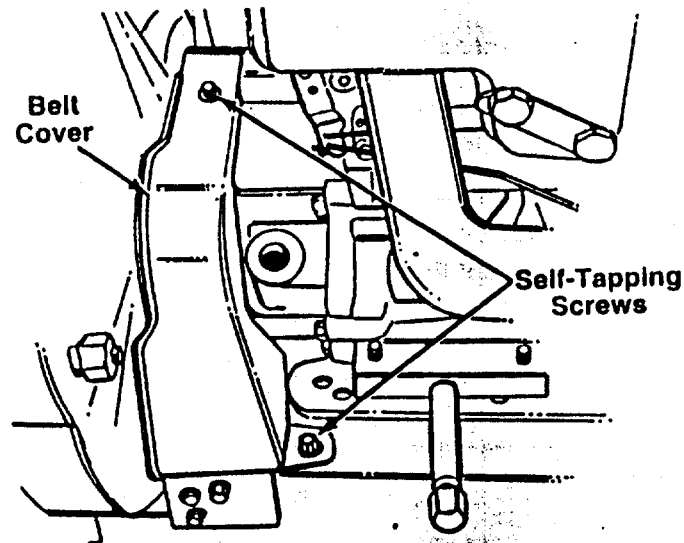

Fig. 3

5. Remove the access plate by removing the two hex lock nuts that secure it to the housing. See Figure 4.

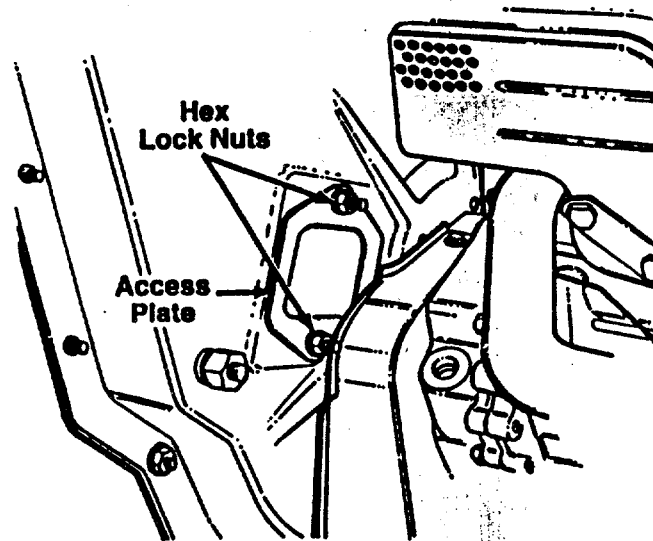

Fig. 4

6. Locate one of the chipper blades in the access plate opening by rotating the impeller assembly by hand. Remove the blade using a 3/16" allen wrench on the outside of the blade and a 1/2" wrench on the impeller assembly, inside the housing.
7. Remove the other blade in the same manner.
8. Position shim against the impeller and re-install blades with the hardware removed in step 6. Torque hardware to 250-350 inch pounds.

NOTE: Make certain the blades are reassembled with the sharp edge facing upward, as viewed from the access opening.

8. Re-install the chipper chute and insure proper clearance has been obtained between the chipper blade and chute anvil. This dimension should be checked with a regular automotive type feeler gauge. The proper setting should range between .060 and .150 clearance.
9. Re-install the flail screen making certain the curved side is down. See figure 2.

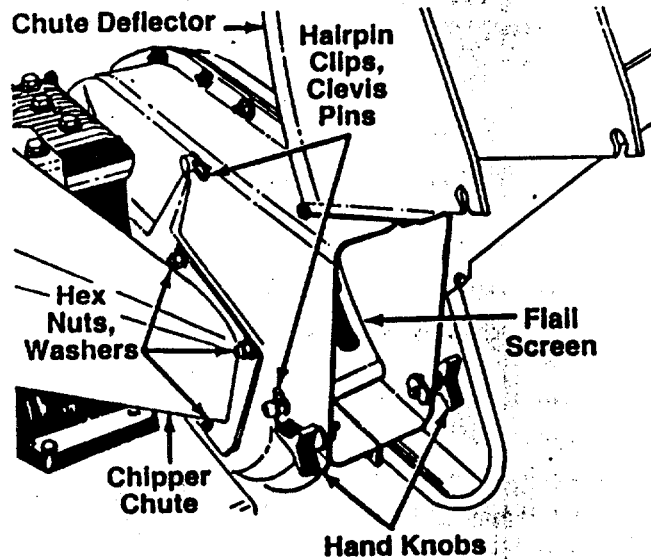

Fig. 2

10. Lower the chute deflector and secure in position by tightening the two hand knobs on each side of the housing.
11. Carefully rotate the impeller to insure that there is adequate clearance between the chipper blade and the chute assembly anvil.
12. Reconnect the spark plug wire.

CHIPPER-SHREDDER-VACUUM
SHIM INSTALLATION
INSTRUCTIONS

Use Service Kit Number 753-0673 when experiencing chipping difficulty.

Install Service Kit as follows:

1. Disconnect the spark plug wire and move it away from the spark plug.
2. Remove the vacuum bag from the unit.
3. Remove the flail screen by removing the four self-tapping screws from the bottom of the discharge chute. Lift off the discharge chute assembly from the unit. See figure 1.

NOTE: BE CAREFUL NOT TO DROP THE HARDWARE INTO THE CHUTE

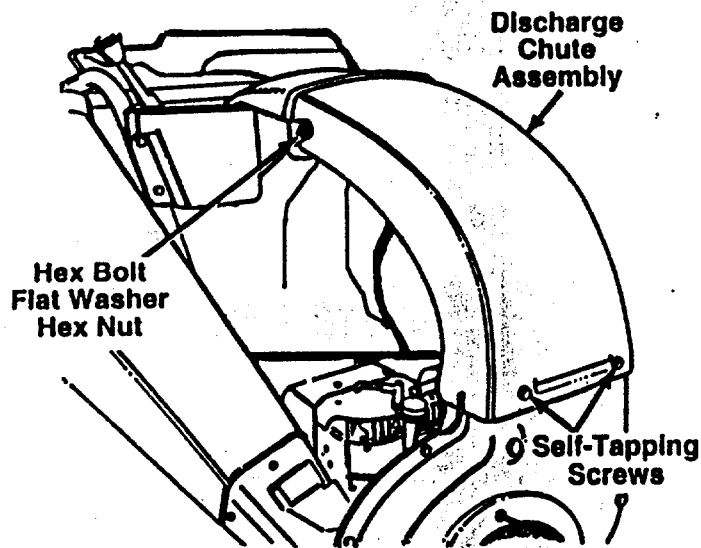

Fig. 1

Remove the two hex bolts and hex nuts which extend through the housing. Lift the flail screen from inside the housing. See figure 2.

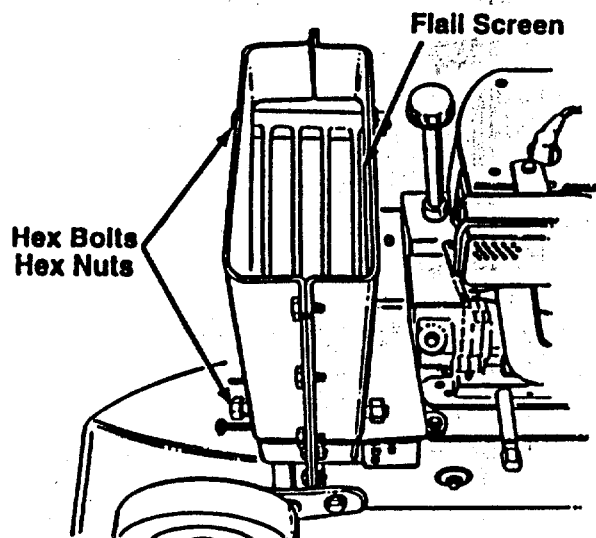

Fig. 2