

Homelite®

GB PARTS LIST

F LISTE DE PIÈCES

D TEILELISTE

I ELENCO DEI PEZZI

E LISTA DE PIEZAS

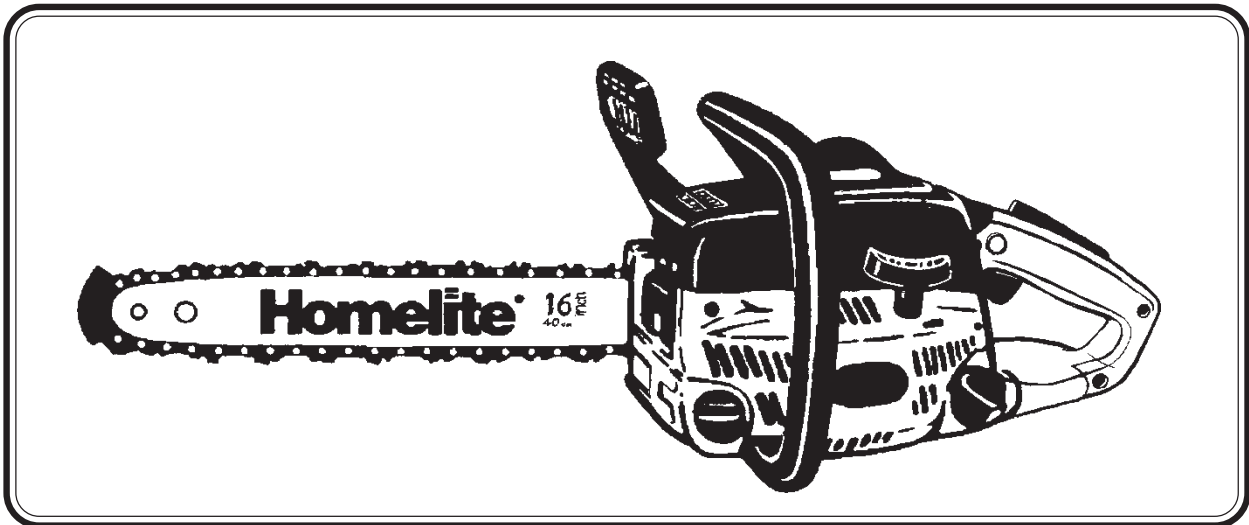

Models

d3300	UT10779, A, UT10821
d3300c	UT10784, A, UT10828
n3014	UT10799R, UT10932
n3014 w/cc	UT10799R1, UT10933
PS33	UT10788, UT10819
z3300	UT10782
z3300c	UT10786, UT10809
20	UT10782A, UT10817
20 w/cc	UT10786A, UT10818

Models

d3800	UT10780, A
d3800c	UT10783, A
n3316	UT10800R, UT10935
z3800	UT10781
z3800c	UT10785
23	UT10781A
23 w/cc	UT10785A
23 w/cc	UT10815, UT10842

P/N PS05010

STARTER - IGNITION

d 3300	(33cc)
d 3300c	(33cc)
z 3300	(33cc)
z 3300c	(33cc)
PS33	(33cc)
n3014	(33cc)
20	(33cc)
d 3800	(38cc)
d 3800c	(38cc)
z 3800	(38cc)
z 3800c	(38cc)
n3316	(38cc)
23	(38cc)

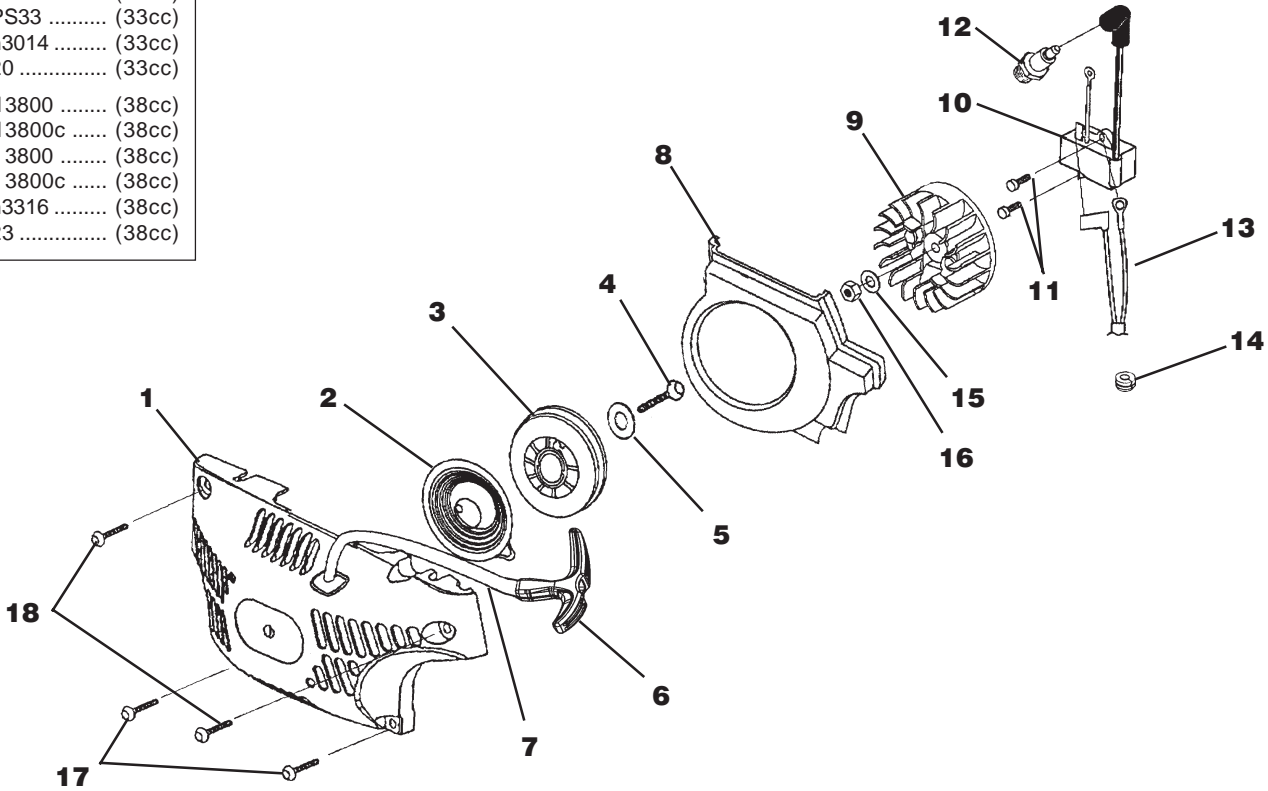

NO.	PART NO.	DESCRIPTION	QTY.
1	•UP 06749	Starter Kit	1
2	UP 04092	Spring & Container	1
3	UP 05460	Pulley, Starter	1
4	UP 04237	Screw, Thread Form, Plastite (10-14 x 5/8")	1
5	UP 04089	Washer, Retaining	1
6	UP 04216	Grip, Starter	1
7	UP 03911	Rope, Starter 46"	1
8	UP 04192	Baffle, Fan Housing	1
9	UP 04242	Rotor & Starter Pawl	1
10	• A 08676 A	Ignition Kit (33cc models)	1
	UP 05851	Ignition Kit	1
11	UP 04086	Screw, Thread Form (8-32 x 5/8")	2
12	UP 04093	Spark Plug	1
13	UP 04222	Ignition Switch Harness	1
14	UP 04215	Grommet, Wire Harness (Split)	1
15	UP 04241	Washer, Flat	1
16	UP 04081	Nut, Jam	1
17	UP 04236	Screw, Truss Hd., Plastite (10-14 x 7/8")	2
18	UP 04237	Screw, Truss Hd., Plastite (10-14 x 5/8")	2

Torque Specs			
Item No.	In/Lbs	Nm	Required Loctite
4	30-40	3.4-4.5	
11	30-40	3.4-4.5	242 Blue
12	120-180	13.6-20.3	
16	100-150	11.3-16.9	
17	30-40	3.4-4.5	
18	30-40	3.4-4.5	

Warranty Flat Rate		
Job	Description	Time/Hr.
FA11	Solid State Module	0.3
FA12	Ground Wire Harness	0.3
FG10	Starter Assy	0.3

d 3300	(33cc)
d 3300c	(33cc)
z 3300	(33cc)
z 3300c	(33cc)
PS33	(33cc)
n3014	(33cc)
20	(33cc)
d 3800	(38cc)
d 3800c	(38cc)
z 3800	(38cc)
z 3800c	(38cc)
n3316	(38cc)
23	(38cc)

ENGINE INTERNAL - OIL PUMP

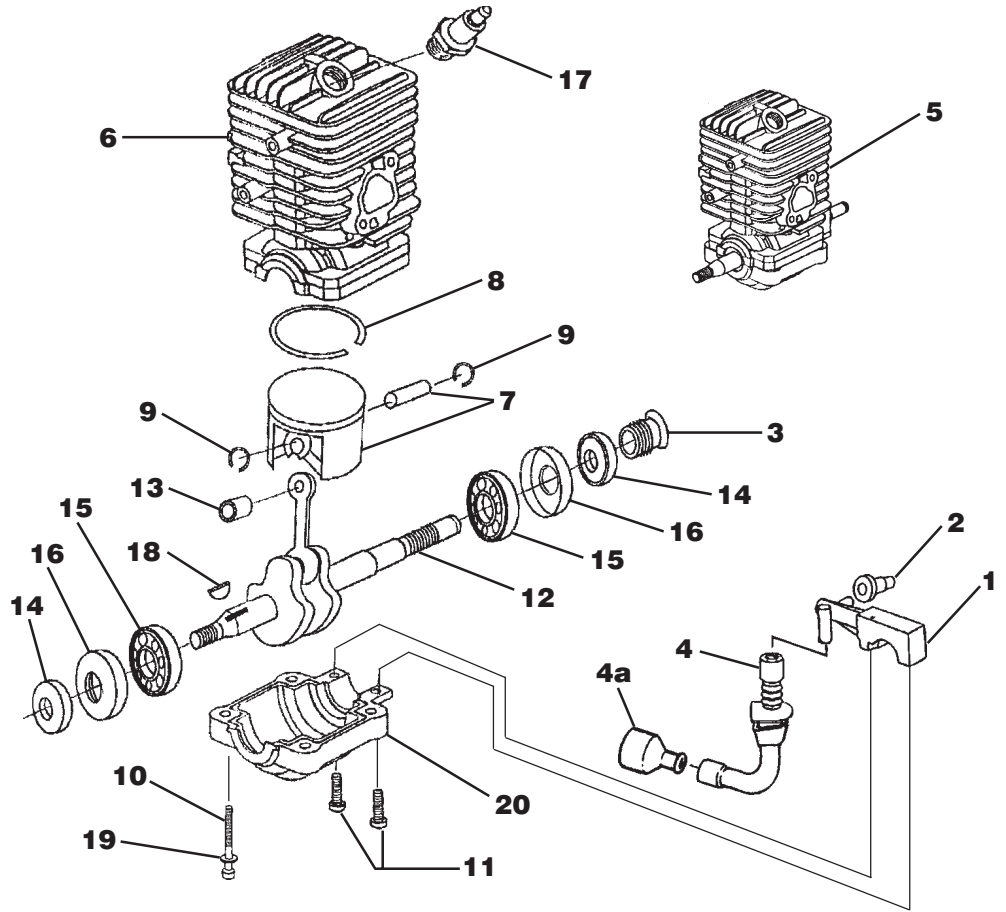

NO.	PART NO.	DESCRIPTION	QTY.
1	•UP 06602	Oil Pump Kit	1
2	UP 04185	Grommet, Oil Outlet	1
3	UP 04188	Left Hand Worm	1
4	UP 04048	Tube, Oil Intake	1
4 a	UP 04054	Oil Filter	1
5	•UP 03696	Short Block, Complete (33cc)	1
	UP 03853	Short Block, Complete (38cc)	1
6	• A 08666	Cylinder Kit (33cc)	1
	A 08667	Cylinder Kit (38cc)	1
	UP 04183	Gasket, Muffler (Not Shown)	1
	UP 04184	Gasket, Heat Dam (Not Shown)	1
	UP 04094	Gasket, Carburetor (Not Shown)	1
7	•UP 06971	Piston & Pin (33cc)	1
8	UP 04177	Piston Ring	1
9	UP 04051	Ring, Retaining	2
	•UP 06972	Piston & Pin (38cc)	1
8	UP 04190	Piston Ring	1
9	UP 04051	Ring, Retaining	2
10	UP 04083	Screw, Cap-Socket Hd. (10-24 x 2")	4
11	UP 03898	Screw, Pan Hd., Plastite (8-16 x 5/8")	2
12	•UP 03587	Crankshaft & Rod Assembly	1
13	UP 04174	Bearing, Needle	1
14	UP 04047	Shaft Seal	2
15	•UP 04176	Bearing & Rubber Case	2
16	UP 04046	Rubber Case	1
17	UP 04093	Spark Plug	1
18	UP 03874	Woodruff Key	1
19	UP 04087	Washer	4
20	UP 04172	Lower Crankcase	1

Torque Specs			
Item No.	In/Lbs	Nm	Required Loctite
10	65-75	7.3-8.5	262 Red
11	15-20	1.7-2.3	
17	120-180	13.6-20.3	

Warranty Flat Rate		
Job	Description	Time/Hr.
FE11	Automatic Oiler	1.0
FB10	Partial Engine Rebuild	1.0
FB20	Short Block	1.0
FB15	C/Case Seal (per side)	0.6

- d3300 (33cc)
- d3300c (33cc)
- z 3300 (33cc)
- z 3300c (33cc)
- PS33 (33cc)
- n3014 (33cc)
- 20 (33cc)
- d3800 (38cc)
- d3800c (38cc)
- z 3800 (38cc)
- z 3800c (38cc)
- n3316 (38cc)
- 23 (38cc)

CARBURETOR - MUFFLER - AIR FILTER

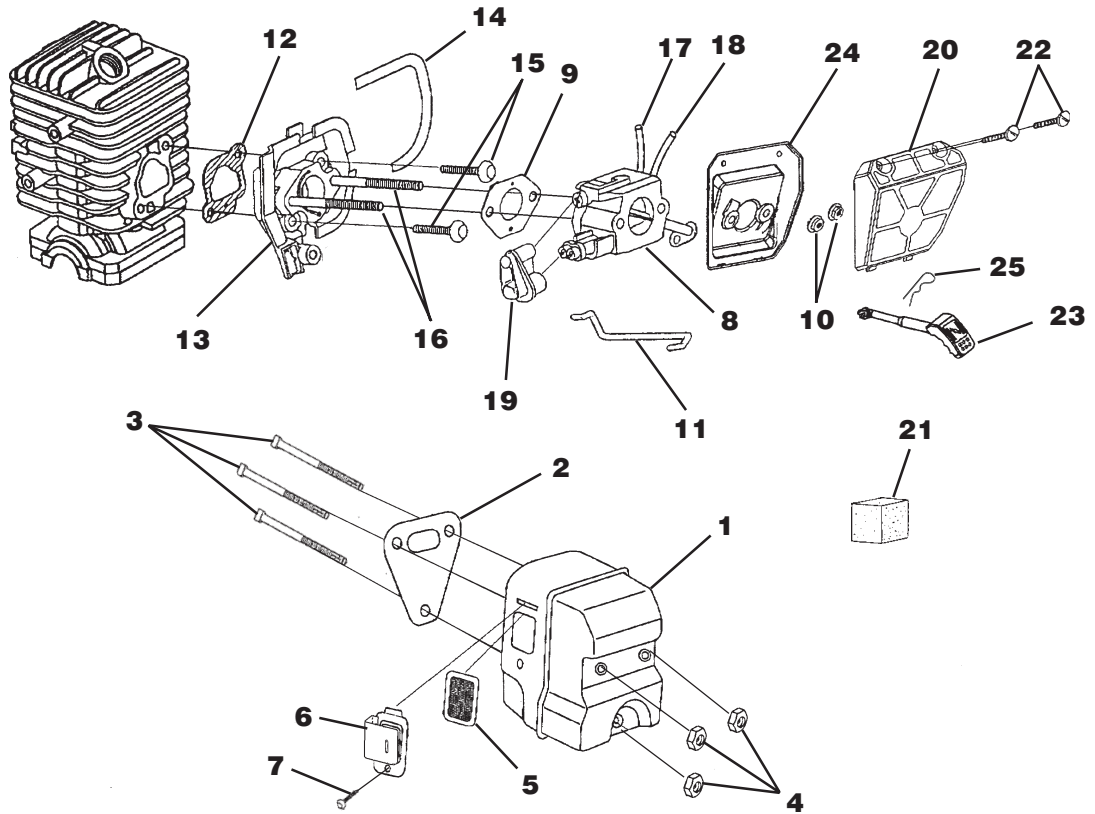

NO.	PART NO.	DESCRIPTION	QTY.
1	•UP 06752	Muffler Kit	1
2	UP 04183	Muffler Gasket	1
3	UP 04049	Screw-Square Hd.	3
4	UP 04059	Nut-Locking Hex (10-32)	3
5	UP 04203	Screen, Spark	1
6	UP 04204	Deflector, Muffler	1
7	UP 04244	Screw (8-32 x .312)	1
8	• A 09159	Carburetor Assembly	1
9	UP 04094	Carburetor Gasket	1
10	UP 04217	Flange Nut (10-24)	2
11	UP 04230	Throttle Wire	1
12	UP 04184	Gasket, Heat Dam	1
13	UP 04173	Heat Dam	1
14	UP 04191	Seal, Heat Dam	1
15	UP 04084	Screw, Truss Hd. Taptite (10-24 x 7/8")	2
16	UP 04189	Screw, Carburetor	2
17	UP 04211	Fuel Line (Tank to Carburetor 8 1/2")	1
18	UP 04209	Fuel Line (Carburetor to Purge Bulb 4")	1
19	UP 04171	Carburetor Grommet	1
20	•UP 06753	Air Filter Kit	1
21	UP 04533	Air Filter Cover	1
22	UP 04208	Pre Filter (In engine housing)	1
23	UP 04235	Screw-Slotted Pan Hd. (8-16 x 5/8")	2
24	UP 04213	Rod, Choke	1
25	UP 04178	Air Filter Plate	1
	UP 04227	Spring Clip (Choke Rod)	1

Torque Specs			
Item No.	In/Lbs	Nm	Required Loctite
4	50-60	5.6-6.7	
10	30-40	3.4-4.5	
15	45-55	5.0-6.2	
22	15-20	1.7-2.3	

Warranty Flat Rate		
Job	Description	Time/Hr.
FB18	Muffler	0.3
FF10	Carb. Replace	0.4
FF12	Fuel Line	0.3
FF44	Air Filter System	0.2
FF17	Heat Dam	0.6
FF15	Choke	0.3
FF13	Throttle Rod	0.5

ENGINE HOUSING - FUEL TANK - OIL TANK

d 3300	(33cc)
d 3300c	(33cc)
z 3300	(33cc)
z 3300c	(33cc)
PS33	(33cc)
n3014	(33cc)
20	(33cc)
d 3800	(38cc)
d 3800c	(38cc)
z 3800	(38cc)
z 3800c	(38cc)
n3316	(38cc)
23	(38cc)

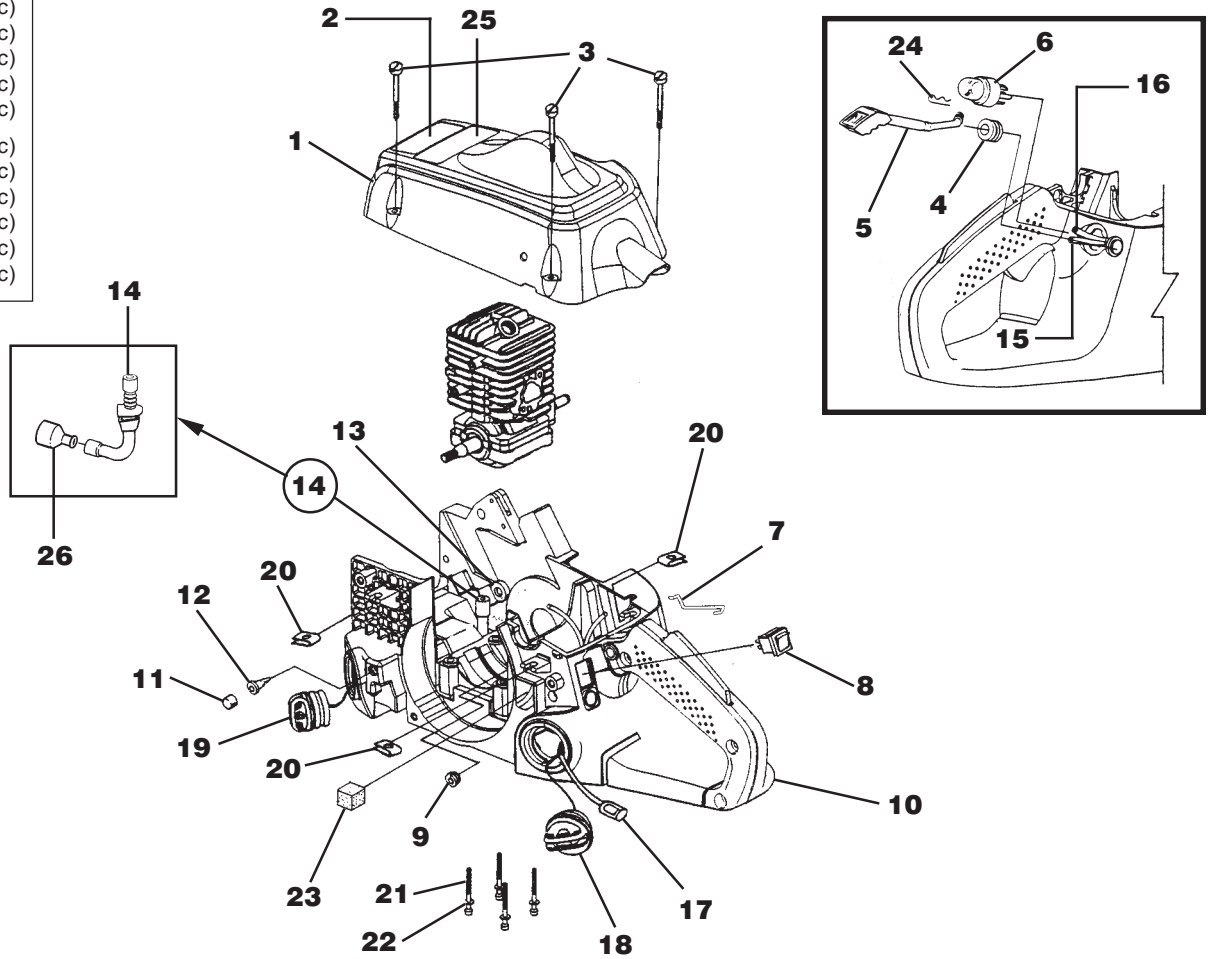

NO.	PART NO.	DESCRIPTION	QTY.
1	• A 09162	Cylinder Cover Kit	1
2	UP 04212	Safety Decal	1
3	UP 04219	Screw-Slotted Pan Hd.	3
4	UP 04052	Grommet	1
5	UP 04213	Rod, Choke	1
6	UP 04033	Bulb, Air Purge	1
7	UP 04230	Throttle Wire	1
8	UP 04197	Switch, Rocker	1
9	UP 04215	Grommet-Split	1
10	• UP 06751	Engine Housing	1
11	UP 04205	Element, Filter (Bronze)	2
12	UP 04045	Duck Bill Valve	2
13	UP 04185	Oil Outlet Grommet	1
14	UP 04048	Oil Intake Tube	1
15	UP 04210	Rubber Tubing (5 1/2")	1
16	UP 04211	Rubber Tubing (8 1/2")	1
17	UP 03871	Fuel Filter	1
18	DA 07590	Fuel Cap w/ Retainer	1
19	DA 07591	Oil Cap w/ Retainer	1
	UP 04054	Oil Filter (Not Shown)	1
	UP 04180	Guide Bar Bolt (Not Shown)	2
20	UP 04221	Speed Nut ("U-Type")	3
21	UP 04083	Screw, Cap-Socket Hd. (10-24 x 2")	4
22	UP 04087	Washer	4
23	UP 04208	Pre Filter	1
24	UP 04227	Spring Clip (Choke Rod)	1
25	UP 04225	Kickback-Decal	1
26	UP 04054	Oil Filter	1

Torque Specs			
Item No.	In/Lbs	Nm	Required Loctite
3 15-25 1.7-2.8	
21 65-75 7.3-8.5 262 Red

Warranty Flat Rate		
Job	Description	Time/Hr.
FD12	... Eng. Hsg. 1.5
FF12	... Fuel Line3
FD90	... Eng. Cyl. Cover 0.3
FF14	... Primer Bulb Assy. 0.3
FF15	... Choke Rod 0.3
FE12	... Oil Line 0.5
	Oil Tank,	
	Use Job FD12 1.5
	Fuel Tank,	
	Use Job FD12 1.5
FA17	... Ignition Switch 0.3

CLUTCH - HAND GUARD - DRIVE CASE COVER

- d3300 (33cc)
- d3300c (33cc)
- z 3300 (33cc)
- z 3300c (33cc)
- PS33 (33cc)
- n3014 (33cc)
- 20 (33cc)
- d3800 (38cc)
- d3800c (38cc)
- z 3800 (38cc)
- z 3800c (38cc)
- n3316 (38cc)
- 23 (38cc)

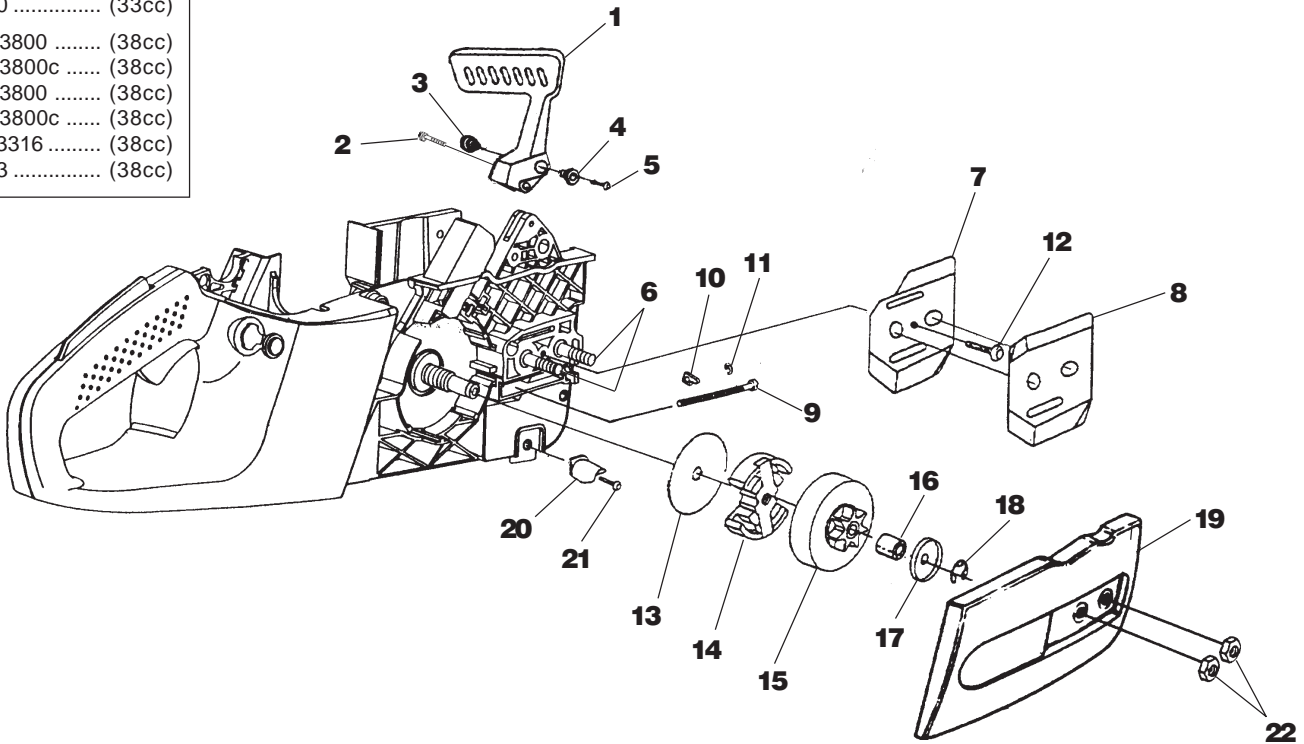

NO.	PART NO.	DESCRIPTION	QTY.
1	• UP 06568	Hand Guard Kit	1
2	└ UP 03898	Screw-Thd. form. (#8-14 x .625)	1
3	UP 04202	Pivot, L.H.	1
4	UP 04201	Pivot, R.H.	1
5	UP 04240	Screw, Hex Socket Hd. (8-32 x 5/8")	1
6	UP 04180	Guide Bar Bolt	2
	• UP 06966	Guide Bar Adjusting Kit	1
7	UP 04206	Plate, Guide Bar	1
8	UP 04085	Plate, Guide Bar	1
9	UP 04187	Screw, Guide Bar Adjusting	1
10	UP 04186	Pin, Guide Bar Adjusting	1
11	└ UP 04056	Ring, Retaining	1
12	UP 04082	Screw, Thread Form., Plastite (6-19 x 1/2")	1
13	UP 04182	Thrust Washer	1
14	UP 06727	Clutch & Hardware	1
15	• UP 06967	Sprocket, Drum (3/8 Pitch)	1
16	UP 04175	Bearing, Needle	1
17	UP 04179	Washer, Cupped	1
18	└ UP 04228	Ring, Retaining	1
19	• UP 06975	Drive Case Cover	1
20	UP 04088	Stop, Chain	1
21	└ UP 03900	Screw, Thread Form., Plastite (10-14 x 3/4")	1
22	UP 04058	Nut, Hex	2

Item No.	Torque Specs		Required Loctite
	In/Lbs	Nm	
5	25-35	2.8-3.9	242 Blue
12	8-18	0.9-2.0	
14	130-180	14.7-20.3	
21	30-50	3.4-5.6	
22	Hand Tight		

Warranty Flat Rate		
Job	Description	Time/Hr.
FC10	Clutch Assy.	0.3
FK10	Guide Bar, Shims Adj.	0.3
FK11	Guide Bar Studs	1.0
FD97	Handguard	0.3
FC12	Sprocket/Ring	0.3

HANDLES

d 3300	(33cc)
d 3300c	(33cc)
z 3300	(33cc)
z 3300c	(33cc)
PS33	(33cc)
n3014	(33cc)
20	(33cc)
d 3800	(38cc)
d 3800c	(38cc)
z 3800	(38cc)
z 3800c	(38cc)
n3316	(38cc)
23	(38cc)

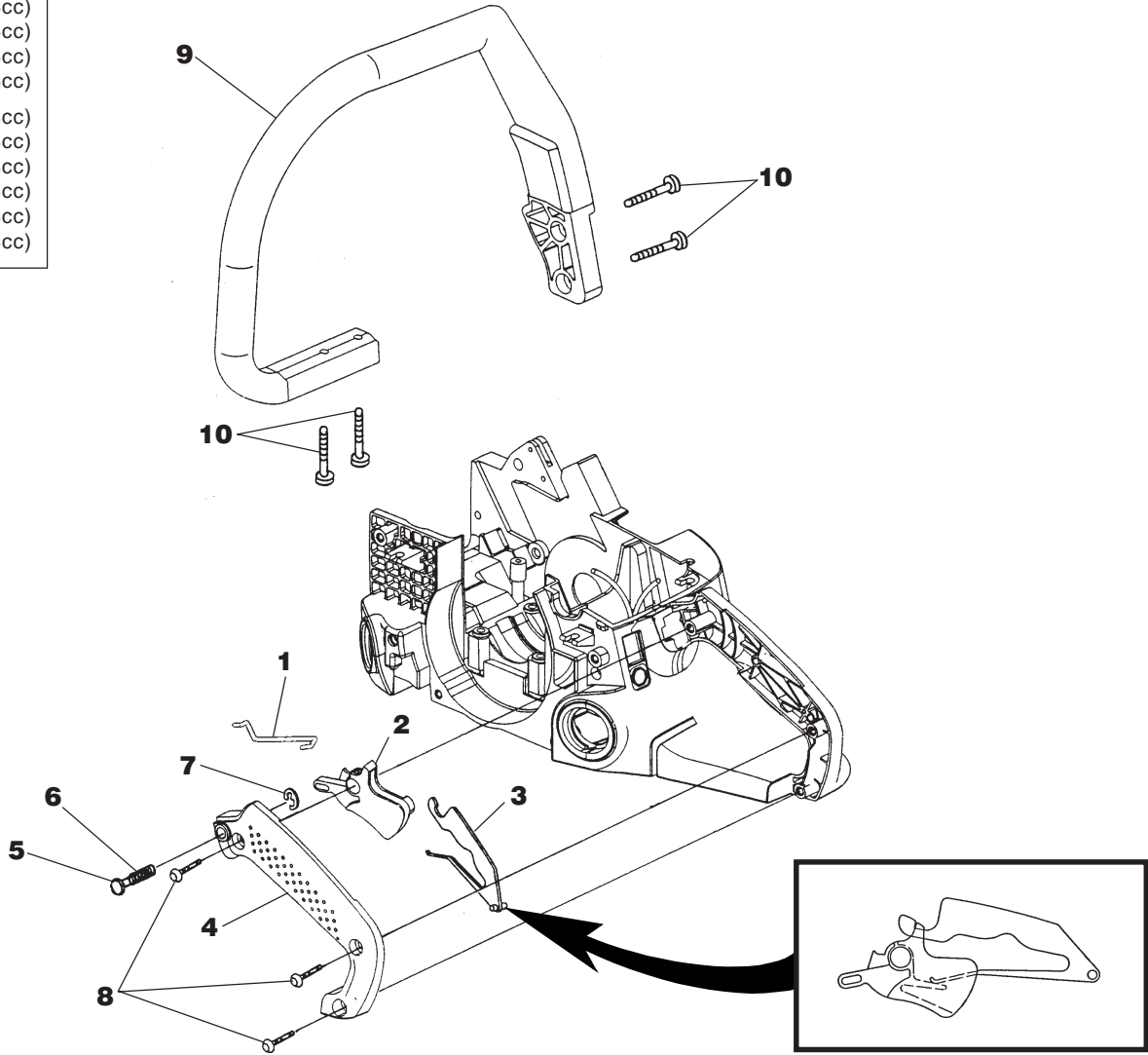

NO.	PART NO.	DESCRIPTION	QTY.
1	UP 04230	Throttle Wire	1
2	UP 04229	Trigger, Throttle	1
3	UP 04196	Throttle Lock Out	1
4	• UP 06736	Handle Cover Kit	1
5	UP 04243	Throttle Lock Pin	1
6	UP 04226	Spring, Compression	1
7	UP 04050	Ring, Retainer	1
8	UP 03900	Screw, Thread Form., Plastite (10-14 x 3/4")	3
9	• UP 06974	Front Handle Kit	1
10	UP 03895	Screw, Plastite (10-14 x 5/8")	4

Item No.	Torque Specs		Required Loctite
	In/Lbs	Nm	
8	30-40	3.4-4.5	
10	30-40	3.4-4.5	

Warranty Flat Rate		
Job	Description	Time/Hr.
FD20	Handle Bar	0.3
FF13	Throttle Rod/Trigger	0.5
FD24	Rear Handle Assy.	
	Use Job FD12	1.5

ACCESSORIES

Guide Bar (Power Tip)		Chain
12"	PT 12371-MD (3/8")	H1 N7245 AH (3/8")
14"	PT 14371-MD (3/8")	H1 N7252 AH (3/8")
16"	PT 16371-MD (3/8")	H1 N7256 AH (3/8")
18"	PT 18371-MD (3/8")	H1 N7262 AH (3/8")

Sealant Silicon PS 24823
Rubber tubing (10') UP06561
Wrench - Combination 09207
Digital Tachometer 18416
Grease, Multi-purpose 18453

Compression Tester 94194
Bit, Torx T27 UP07160
Carry Case UP04562
Bumper Spike Kit UP06732

For product information, technical help, dealer locations or parts ordering information visit our website at:
www.homelite.com.

John Deere Consumer Products Limited
Produits Consommateurs John Deere Limitée

1850-55e/th Avenue
Lachine, Québec, Canada H8T 3J5
tel: 1-514-636-5900 / fax: 1-514-636-9966

John Deere Consumer Products International B.V.

Haverstraat 24
2153 GB Nieuw Vennep
The Netherlands
tel: +31-252-687342 / fax: +31-252-687993

John Deere Limited

A.C.N. 008 671 725
166-170 Magnesium Drive
Crestmead, Queensland 4132
Australia
tel: 61-7-3802-3222 / fax: 61-7-3803-6555

JOHN DEERE
WORLDWIDE COMMERCIAL & CONSUMER EQUIPMENT DIVISION

4401 Bland Road, Suite 200
Raleigh, NC 27609

Phone 1-800-537-8233

Homelite Parts